

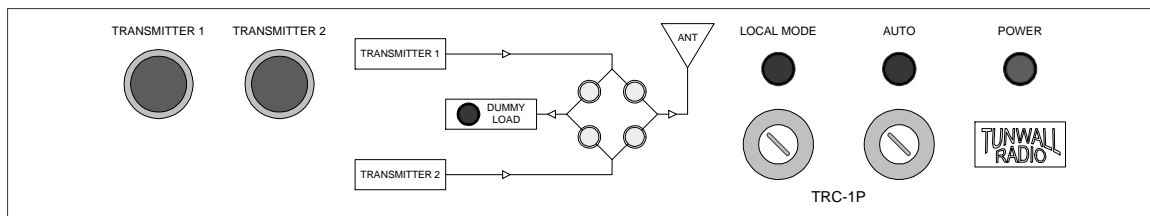

330-995-9642

INSTALLATION AND SERVICE MANUAL



TRC-1P

COAXIAL SWITCH CONTROLLER

Oct 2010



TRC-1P FM switch controller – general	2
Controller connections	3
Remote command inputs	3
Remote control status outputs	3
Transmitter interlocks	3
Dummy load connections	4
Plate on and off connection	4
Switch position tally connections	4
Motor control voltage	5
Auto transfer connections.....	5
OPERATION	6
Front panel status indicators	7
Load interlock	7
Fuses	7
Auto transfer	7
Auto transfer cont	8
Controller schematic diagram 1	9
Controller schematic diagram 2	10
Interconnection chart for 50000 and 60000	11
Additional coax switches	12
Component layout	13
50000 coax switch manual	7 pages
60000 coax switch manual	10 pages

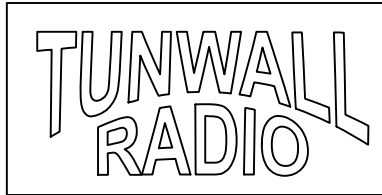

www.tunwallradio.com
330-995-9642

TRC-1P CONTROLLER

The TRC-1P is a controller for one coax switch, two transmitters, one antenna, and a dummy load. It is compatible with Dielectric, Delta, Andrew, ERI and MCI coax switches, or any other switch with 12VDC, 24VDC, or 120VAC position command inputs. The controller can also be used with AM RF contactors, directly if the contactor is 120VAC or with pilot relays for 240VAC. An alternate program is usually loaded into the PLC for use with AM contactors, which can speed up transmitter changes, although this is not required.

This controller is the same as the standard TRC-1, with the addition of plate on and off closures for both transmitters. It is a PLC-based coaxial switch and transmitter interlock controller. Switch timing and transmitter interlocks are controlled by a NAIS FP0-C14RS programmable logic controller.

The PLC uses EEPROM for program memory. No backup battery is required, so program loss should not be a concern, even if the controller is unplugged for months or years.

The 24 volt power supply illuminates front panel indicators, energizes DC coax switch relays, and provides operating and input common voltage for the PLC.

The controller's AC and DC fuses are located on the rear of the unit. The DC fuse is 1/2 A. The AC fuse is 3A. If a Dielectric 50000 switch is used, the AC fuse should be about 3A. For other coax switches that do not get motor power through the controller, a 1A fuse could be used.

The coax switch or RF contactor is connected to a 9-pin AMP socket on the rear panel. All other connections are made to barrier strip terminals.

CONTROLLER CONNECTIONS

Schematic drawings and interconnection charts are provided for Dielectric 50000 and 60000, Andrew, Delta, and MCI coax switches. Some variations in non-Dielectric internal wiring turn up occasionally, so wiring should be verified if the original switch documentation is available. Connections to the coax switch are on the 9-pin AMP socket. All other connections are to barrier strip terminals.

REMOTE COMMAND INPUTS

Controller terminals TB1-1 to TB1-3 are the remote position select connections. Floating relay contacts are best, but open collector equipment may be compatible depending on its polarity and operating voltage.

REMOTE CONTROL STATUS OUTPUTS

The remote control status outputs, terminals TB1-4 to TB1-6, are connected through diodes to the front panel status indicators. The PLC used in the controller has a limited number of outputs, so the two status functions are combined. The remote control status outputs are compatible with most remote control systems, The only requirement is that one state of the circuit is ground or near ground. The PLC output relays cause terminals TB1-2 and TB1-3 to go near ground when a remote status indication is desired. The series diodes keep the controller's front panel indicators from lighting through the remote control's pull-up resistors.

TRANSMITTER INTERLOCKS

The transmitter interlock terminals, TB1-15 to TB1-18, are connected to the interlock or mute terminals of the transmitter(s). Older transmitters that do not have terminals designated for this purpose may have connections for remote plate off. If this circuit requires a continuous closure to keep the plate on, the controller's interlock terminals may be wired in series with the transmitter/remote control circuit.

In older transmitters the interlock or remote plate off circuit may be 120VAC. The PLC relays are rated for 250VAC (at 2A). The installer should decide whether to connect AC control circuits to the controller. It is generally recommended to install DC relays in the transmitter.

The interlock logic (normally open/normally closed) can be reversed with internal jumper plugs, as shown on the component layout page.

DUMMY LOAD CONNECTION

The tally terminals of a dummy load should be connected to controller terminals TB1-7 and TB1-8. The PLC has been programmed to operate correctly with a dummy load contact closure when the blower or water is “on”. This allows the transmitter not on-air to be energized, for load testing.

When the load interlock function is not being used, the off-air transmitter is muted. Its filament and blowers should be able to operate.

The local key switch is not required for routine load testing. If a transmitter change occurs while load testing the off-air transmitter, both transmitters will be muted while the switch is moving.

With a convection load, an external switch should be connected to the load interlock terminals. A switch is usually preferable to a permanent jumper, so that when the site is unattended the off-air transmitter is not allowed to run into the load.

An external load interlock switch might also be desirable with Altronic loads. This is due to the nature of their tally contact operation – whenever power is applied, their tally contacts close, and will open only if the load overheats. This could allow operator error to turn on an off-air transmitter. While the load would theoretically not be damaged, the heat from the extra transmitter and the load could cause problems in many transmitter buildings, given some time. As an alternative to an external load interlock switch, the Altronic load could be disconnected from power when the site is unattended.

PLATE ON AND OFF CONNECTIONS

Plate on and off closures have been added to the standard TRC-1 to make the TRC-1P. Terminals TB2-1 to TB2-8 are the 4 closures. The plate off closures are momentary, and operate immediately when either transmitter change command is issued. The plate on closures are momentary, and operate when the switch sequence is complete, at the same time the transmitter interlock is restored.

SWITCH POSITION TALLY CONNECTIONS

The controller needs to know which position the coax switch is in, to operate the transmitter interlock closures and position change commands. These connections are made to AMP connector pins 1-4.

The controller will work with any switch port arrangement. The needed logic is selected by the presence or absence of a terminal strip jumper between terminals TB1-9 and TB1-10.

If transmitter 1 is connected to the antenna when the switch is in position 1, no jumper is needed. If transmitter 1 is connected to the antenna when the switch is in position 2, the jumper is needed.

If the jumper/no jumper is wrong, the front panel position indicator pairs will operate backward, and the wrong transmitter interlock will close.

Note: Dielectric 50000 switches have a mechanical position indicator. Other switches may have a similar indicator. Any switch manual should provide position/port connection drawings.

MOTOR CONTROL VOLTAGE

The controller is compatible with Dielectric 50000 series coax switches that have 12 VDC, 24 VDC or 120 VAC motor control relays. The controller has internal jumper plugs to select control voltage.

The Dielectric 60000 series switch will operate from DC or 120VAC commands, but the cable wiring is different. Generally, DC control is preferred. The controller has internal jumper plugs to select DC or AC command voltage.

Another control option is possible with 60000 series coax switches – if the control board on the switch is damaged or removed, the FM controller can operate the switch by wiring directly to the 3-terminal motor (the controller must be set for 120VAC commands). The 60000 switch motor has one winding for CW, and one for CCW.

Andrew, Delta and MCI coax switches can be used with the controller, using a modified connection chart, provided as needed.

AUTO TRANSFER CONNECTIONS

The key switch selected auto transfer will change to transmitter 2 if transmitter 1 fails, and will turn on transmitter 2. To use auto transfer, a transmitter 1 “on” signal must be provided to the controller. This can be done two ways; a floating contact closure (closed = on), or a 5 volt signal capable of about 70mA (5 volts = on). The 5 volt terminals are connected directly to the coil of a small relay, and not grounded. The 5 volt relay coil has a parallel diode for back voltage suppression, so polarity matters – terminal 12 is positive.

The transmitter 1 “on” closure or 5 volt signal can come from the transmitter or any external device such as an RF power detector or suitable modulation monitor. Circuit modifications or additions may be required. Either signal will light the TX 1 PLT ON indicator on the back of the controller. This indicator should be checked before turning the auto key switch on.

Note: the following transmitter 2 plate on closure is part of the standard TRC-1, which does not have complete plate on/off closures. This closure, a duplicate in the TRC-1, could be used for transmitter 2 plate on, or to control something else.

Auto transfer will turn on transmitter 2 with a momentary relay contact, terminals TB1-19 and TB1-20. This momentary closure comes from a capacitor and relay arrangement. When the transmitter 2 status indicator comes on (in auto only), a 1000 mfd capacitor will charge through the coil of K3, energizing the relay for about 1 second. When the transmitter 2 status indicator is off, the capacitor will discharge in about 30 seconds through a 10k resistor. A series diode keeps the transmitter 2 status indicator pair from lighting through the coil of K3, when transmitter 1 is on the antenna. K3 will not do anything unless the auto key switch is on.

OPERATION

The two front panel pushbuttons are the local controls for selection of transmitters 1 and 2 to the antenna. If the front panel pushbutton for the transmitter already on-air is pushed, nothing will happen. A switch change command locks out the other for the duration of the switching sequence.

The switching sequence is:

- transmitter interlock connections open, 1 second delay
- coax switch operation (as long as it takes up to 30 seconds)
- interlock delay of 0.2 seconds at completion of switch movement (this allows the coax switch settle mechanically)
- transmitter interlock(s) on

During the transfer sequence, the status indicator pair for the position being switched to will flash.

When the coaxial switch is moved manually, the transmitter interlocks will open, protecting the switch and transmitter as much as possible, but this should not be done with transmitter(s) on. The coax switch must move slightly before its position switch is activated, which means that its contacts will be moved slightly under power, which is not desirable. If the switch is moved manually, when it “makes” either position, there will be a 0.2 second delay before the interlock(s) is restored

The controller has terminals for remote position change commands. These work exactly as the front panel pushbuttons unless the controller is in local. In local, only the front panel pushbuttons are active.

FAILURE TO COMPLETE SWITCH

After a switch sequence has been started, if the coax switch doesn't complete its position change, neither interlock will be completed. The controller will then reset after 30 seconds, when the transfer can be attempted again.

If the coax switch does not start to move within 2 seconds after a position change command, and the switch is still in a valid position, the interlock for the correct transmitter will be restored. This is unlikely but might happen if the switch motor AC power connection fails.

FRONT PANEL SWITCH POSITION STATUS INDICATORS

The coax switch position status indicator pairs and flow chart graphic indicate the transmitters' signal path to antenna or load. The switch position number that corresponds to main transmitter on-air depends on which ports the transmitters and antenna or dummy load have been connected to. A logic reverse jumper is described in the switch position tally paragraph in the connections section of the manual.

LOAD INTERLOCK

With fan-cooled or water loads, the tally contacts in the load will allow the off-air transmitter to run, through the controller's load interlock circuit. When the load is on, the front panel dummy load indicator is on, for testing transmitters. With convection loads, an external switch should be connected to the load interlock terminals. If a transmitter change command is given during a load test, the coax switch is protected, because both transmitters will be muted.

FUSES

The rear panel DC fuse, 1/2 A, is on the output of the 24V power supply. The AC fuse is in series with the "hot" lead for the entire controller, and the AC power for the coax switch. This fuse should be about 3A with Dielectric 50000 switches. The installer may choose to use larger fuses. The controller's internal power wiring is 18 ga.

AUTO TRANSFER

The optional key switch selected auto transfer will change to transmitter 2 if transmitter 1 fails. To use auto transfer, the controller requires a continuous signal to indicate that transmitter 1 is on, described in the auto transfer paragraphs in the connections section of the manual. The rear panel transmitter 1 indicator should be checked before turning the auto key switch on.

In auto transfer, if transmitter 1 fails for 5 seconds, the controller will switch to transmitter 2. If transmitter 1 fails for less than 5 seconds but comes back on, the 5 second timer will reset.

Whenever the auto key switch is on, a change to transmitter 2, whether local, remote, or automatic, will not flash the front panel transmitter 2 status indicator pair during the change. The indicators will light normally when the coax switch is in the transmitter 2 position.

Auto transfer may not be appropriate for all stations. Failure of one power line phase might cause an unintended transmitter change, if the rack power didn't drop out. If the transmitter's plate on status is used to provide the "on" signal to the controller and the exciter/IPA fails, there could be nothing on air but the controller would not transfer.

TRC-1P

THE INTERNAL VOLTAGE JUMPERS MUST BE IN THE CORRECT POSITIONS (24 OR 12 VDC, 120VAC)

INPUT AND OUTPUT CONNECTIONS (BLUE) ARE TO DIELECTRIC 50000 SWITCH. SEE INTERCONNECTION PAGES FOR 60000 AND OTHERS.

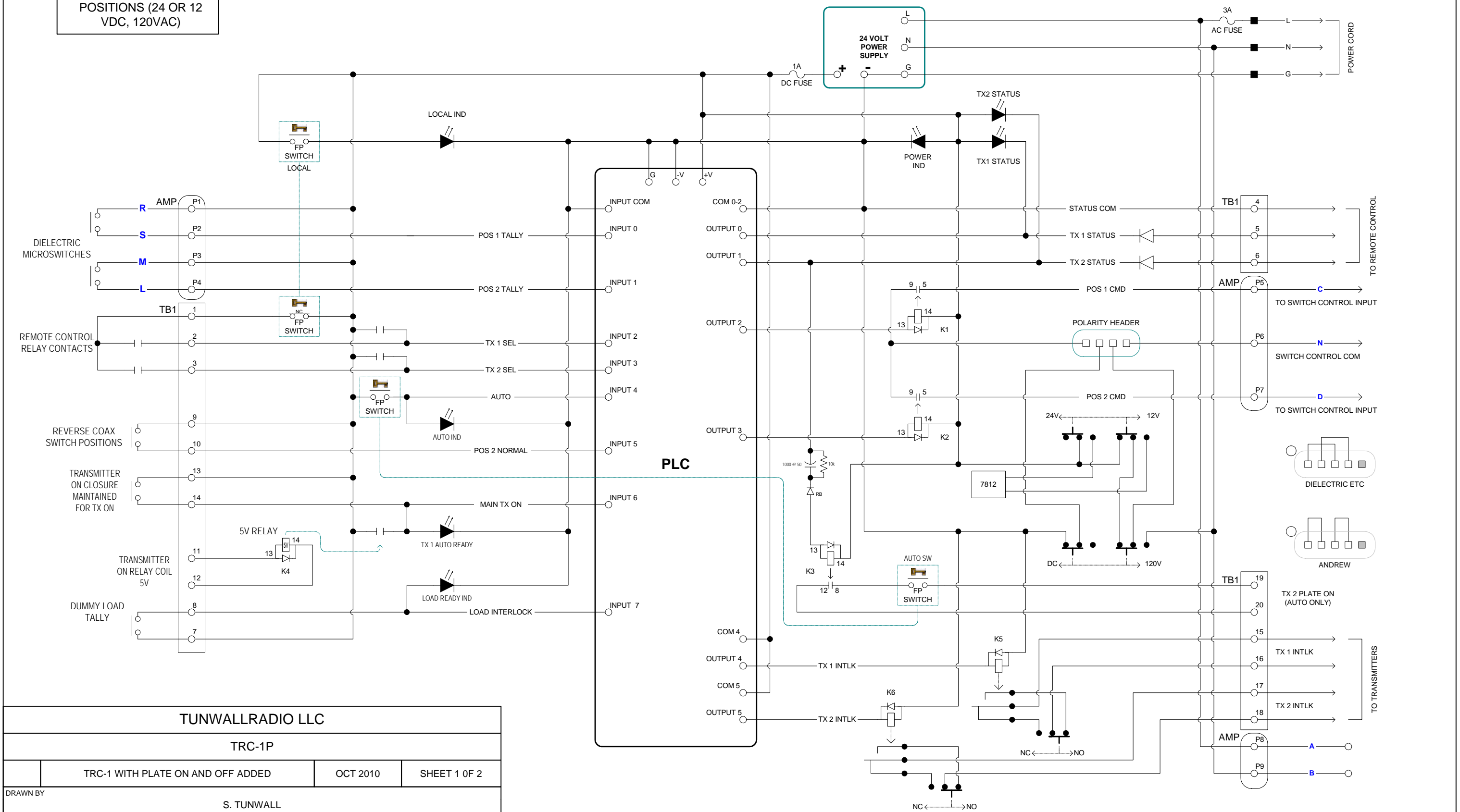

TUNWALLRADIO LLC		
TRC-1P		
TRC-1 WITH PLATE ON AND OFF ADDED	OCT 2010	SHEET 1 OF 2
DRAWN BY S. TUNWALL		

TRC-1P

PLATE ON/OFF CONTROL

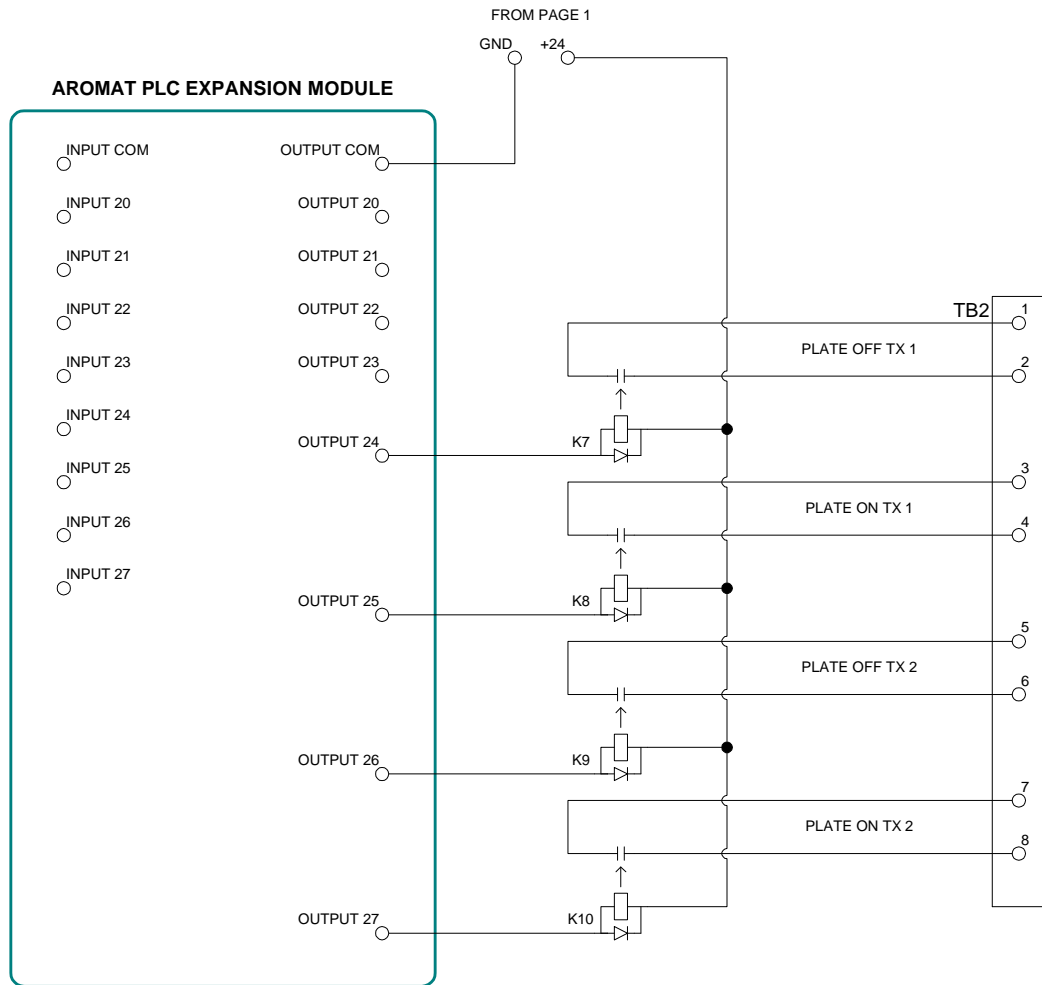

TUNWALLRADIO LLC

TRC-1P

TRC-1 WITH PLATE ON AND OFF ADDED

OCT 2010

SHEET 2 OF 2

DRAWN BY

S. TUNWALL

SWITCH AND REMOTE CONTROL (SUCH AS BURK) CONNECTIONS 50000 AND 60000 SERIES

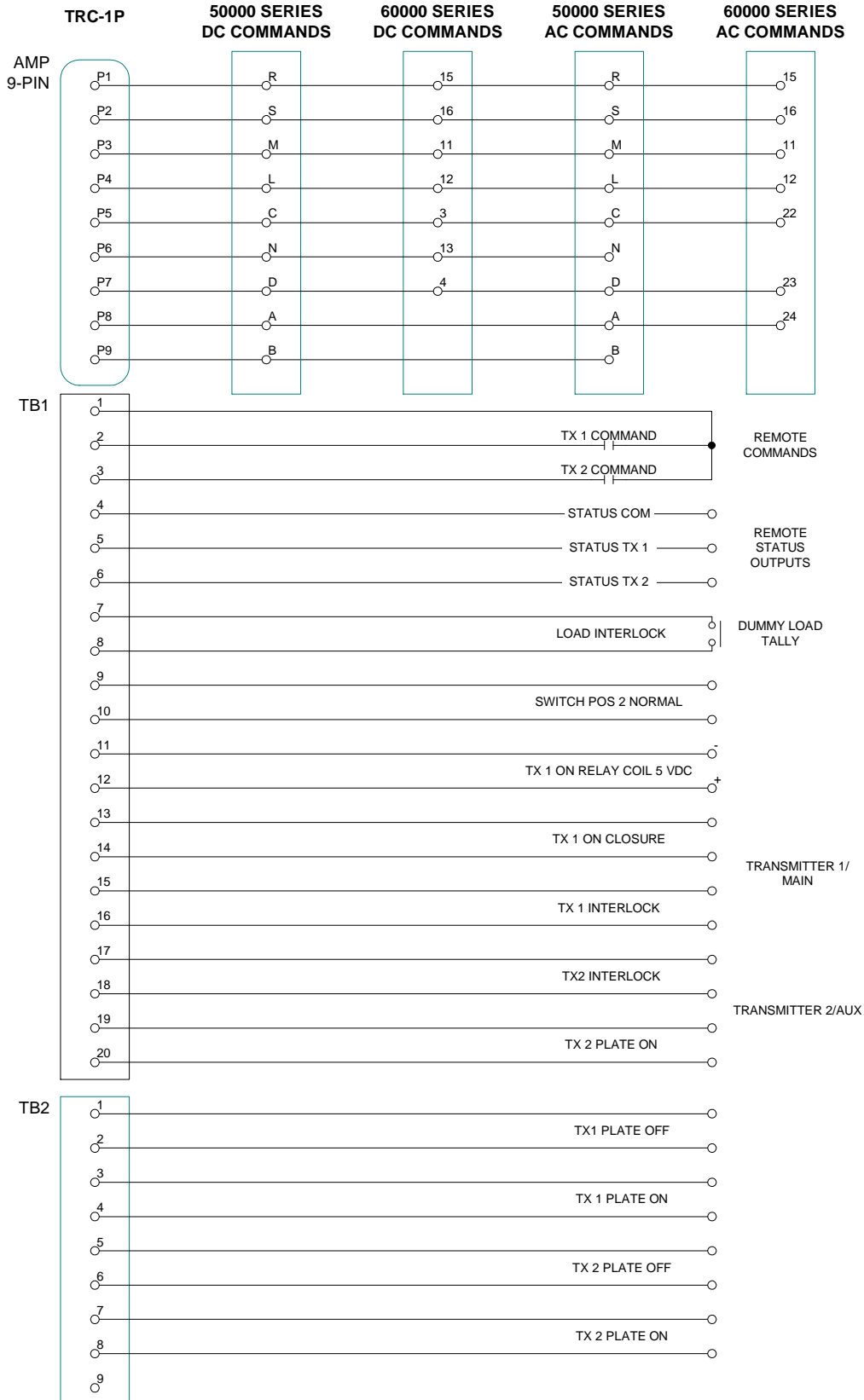

COAX SWITCH CONNECTIONS FOR FM CONTROLLERS

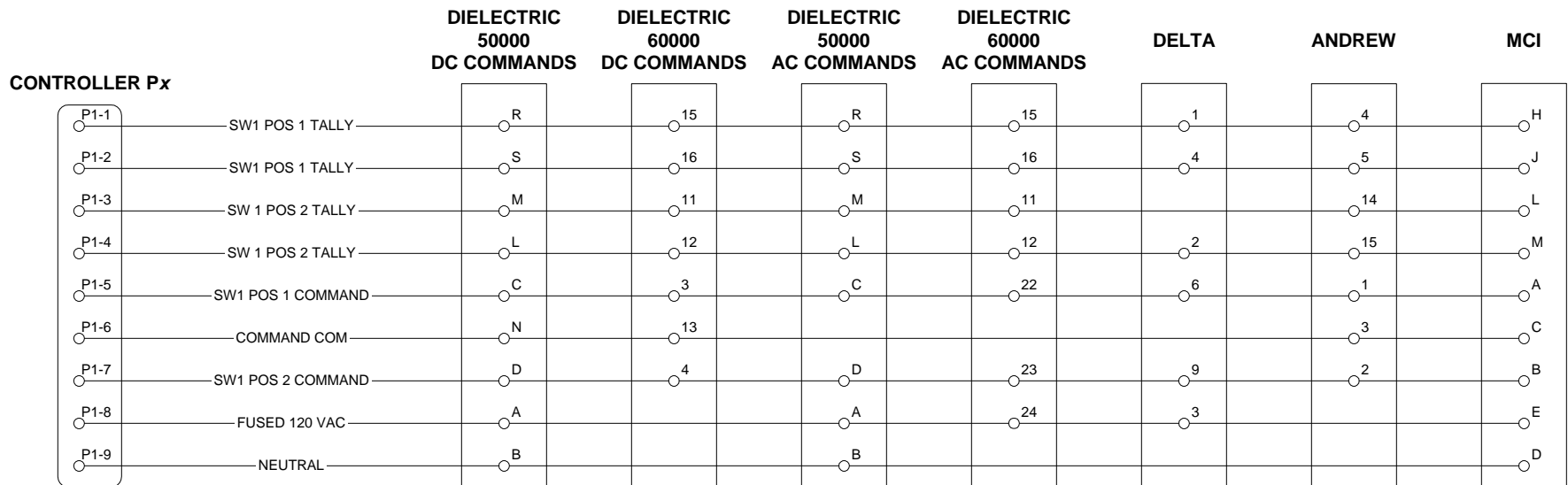

12

ANDREW REQUIRES REVERSE POLARITY HEADER

ANDREW 24VDC ONLY

DELTA 120VAC ONLY

MCI MAY HAVE 5V CONTROL RELAY - CHANGE TO 12V OR 24V

TERMINAL NUMBERS FOR DELTA, ANDREW, MCI MAY NOT BE CORRECT FOR EVERY MODEL

TRC-1P COMPONENT LAYOUT

